

Remote Data Concentrator (RDC) Simulation

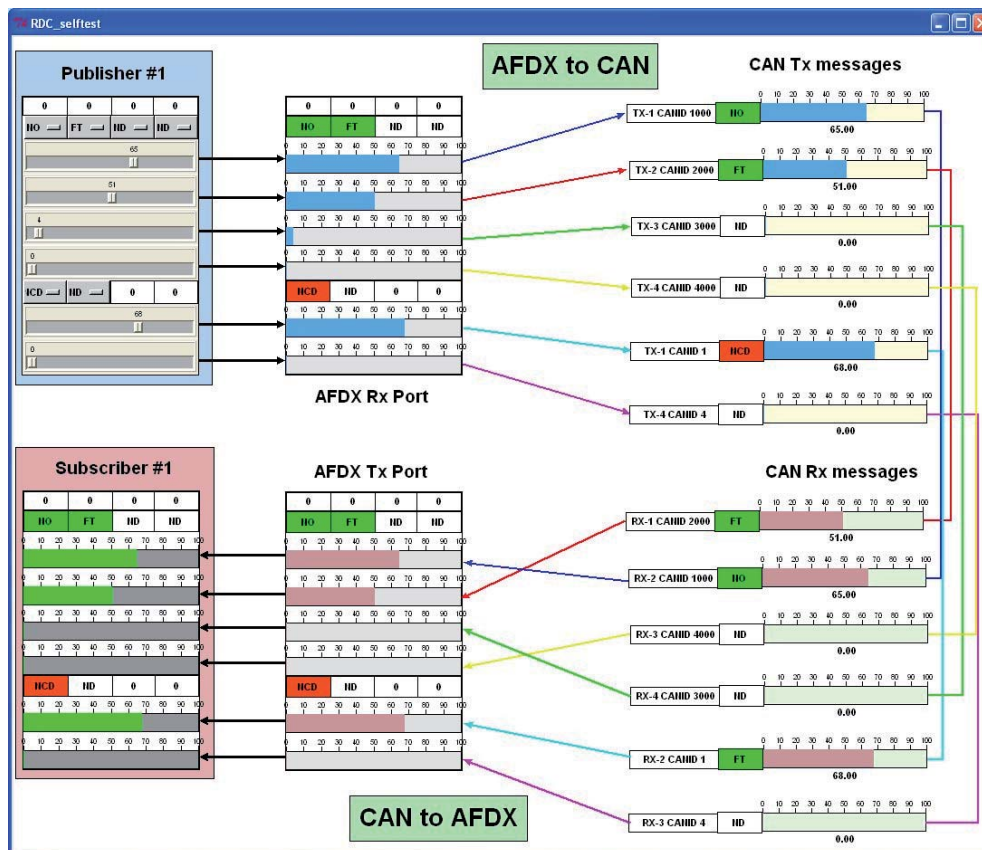

- Remote Data Concentrator (RDC) simulation for e.g. B787 and A350 XWB
- AFDX[®]/ARINC 664 gateway to CAN and vice versa
- AFDX[®]/ARINC 664 gateway to ARINC 429 and vice versa
- Support for dataloading via ARINC 615A and ARINC 826 A/B
- Full event logging during data transfers and complete post load diagnostics
- Optional databus analysis for AFDX[®], CAN and ARINC 429



Remote Data Concentrator (RDC) Simulation

General

The RDC simulation is implemented as a software add-on for the TechSAT Avionics Development System (ADS2). It simulates the functionality of the Remote Data Concentrator as used in e.g. the Boeing 787 and the Airbus A350 XWB. The RDC simulation provides a two-way gateway between AFDX®/ARINC 664 on one side and CAN bus or ARINC 429 on the other side. The RDC concept allows the use of legacy ARINC 429 LRUs in Next Generation aircraft and supports the use of emerging CAN bus networks in avionics applications.

Test and Integration Support

The RDC simulation provides an ideal tool for aircraft network development, test and integration applications. In combination with other TechSAT products, a complete aircraft data network can be built for lab and development purposes. The RDC simulation supports up to ten CAN bus channels and four ARINC 429 channels.

Data Loading Support for CAN bus

The RDC simulation provides full support for ARINC 615A and ARINC 826A data loading over CAN bus. In addition, downstream data loading via ARINC 826B is supported.

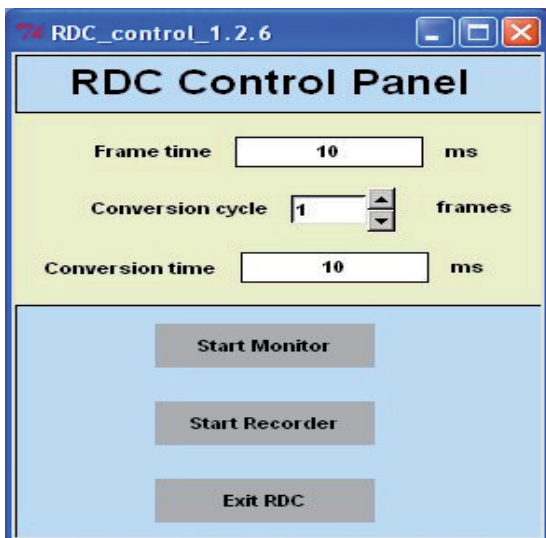

Simulation/Stimulation Support

By using the RDC simulation as a stimulation tool, AFDX End Systems (E/Ss) can be stimulated thereby allowing these to be developed and tested prior to availability of sensors and LRUs with which the AFDX E/Ss communicates. Conversely, CAN bus and legacy ARINC 429 LRUs can be stimulated by the RDC simulation thereby substituting AFDX E/Ss not yet available. As a gateway between avionics networks, the RDC simulation provides an ideal monitoring point. The TechSAT ADS2 platform allows CAN, ARINC 429 and AFDX Analyzer functions to be used in combination with the RDC simulation. This facilitates monitoring of bus traffic on both sides of the gateway in all supported protocols.

RDC Versions

- **RDC-CAN**
CAN version with 2 to 10 channels
- **RDC-ARINC 429**
ARINC 429 version with 2 channels
- **RDC-CAN/A429**
CAN version with 2 to 10 channels &
ARINC 429 version with 2 channels
- **Rover/MST (Multifunction Support Tool)**
CAN Data Loader Version

Optional

- **AFDX®, CAN bus & ARINC 429 analysis**

Distributor

AFDX is a registered trademark of Airbus Deutschland GmbH