

AFDX-PMC

AFDX®/ARINC 664 PMC Module

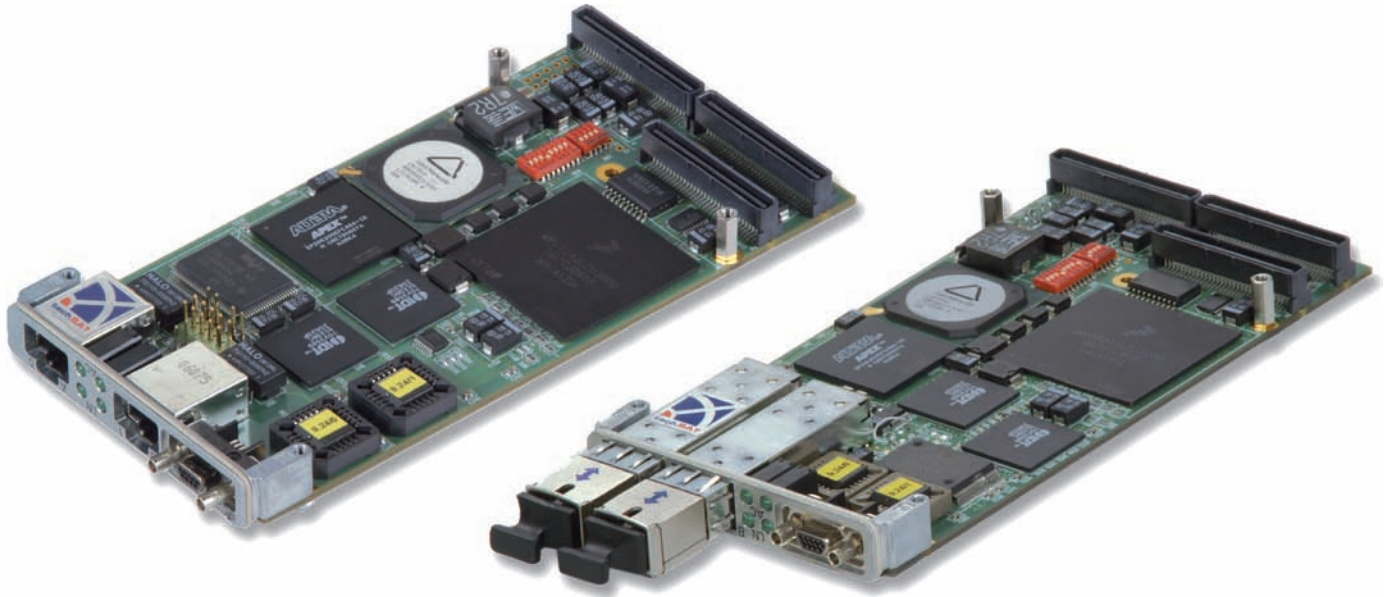

- Airbus or Boeing AFDX® compliant protocol stack
- Dual redundant twisted pair copper or fiber-optic transceivers
- On-board AFDX® protocol stack implementation
- Comprehensive error injection/detection, filtering and triggering features
- Applicable on PCI, cPCI, PXI, PCIe & VME hardware platforms
- Driver & API support for Windows, Linux or VxWorks



AFDX-PMC

AFDX®/ARINC 664 PMC Module

Overview

The TechSAT AFDX-PMC is a powerful AFDX®/ARINC 664 interface implemented on a PMC (PCI Mezzanine Card) form factor module. It implements the AFDX® protocol stack in on-board firmware and FPGA logic thereby off-loading the host. By changing the FPGA logic and firmware versions, the module can be configured to be compliant with either the Airbus or Boeing AFDX® protocol stack.

AFDX-PMC is equipped with two full duplex AFDX networks that can be operated in either independent or dual-redundant mode. The AFDX-PMC connector interface can be either twisted pair copper or bi-directional fiber-optic Small Form-Factor Pluggable (SFP).

In addition to the AFDX® protocol stack, the AFDX-PMC also implements comprehensive test features such as error injection/detection, filtering, triggering and discrete I/O lines. Optimized for performance, the AFDX-PMC is ideal for applications such as AFDX® ES (End System) testing and validation, ES simulation and ARINC 615A data loading via AFDX®.

Software Support

AFDX-PMC is shipped with a C-API and drivers for either Windows, Linux or VxWorks. In addition, several software tools for test, simulation and dataloading purposes are available on request. For test puposes, TechSAT has developed a powerful AFDX® analyzer as well as an AFDX® ES test and validation tool. Furthermore, TechSAT has developed several AFDX® based protocol simulations for the Airbus A380 and A400M as well as for the Boeing 787. Finally, AFDX-PMC also supports the TechSAT tool suite for dataloading over ARINC 615A.

Architecture

As depicted in the block diagram, the host communicates with AFDX-PMC via a dedicated driver. The driver uses I2O and DMA for fast data transfers between the host and AFDX-PMC. The on-board CPU runs the AFDX® protocol stack as well as controlling the FPGA which offloads the CPU by handling Tx scheduling and error injection/detection.

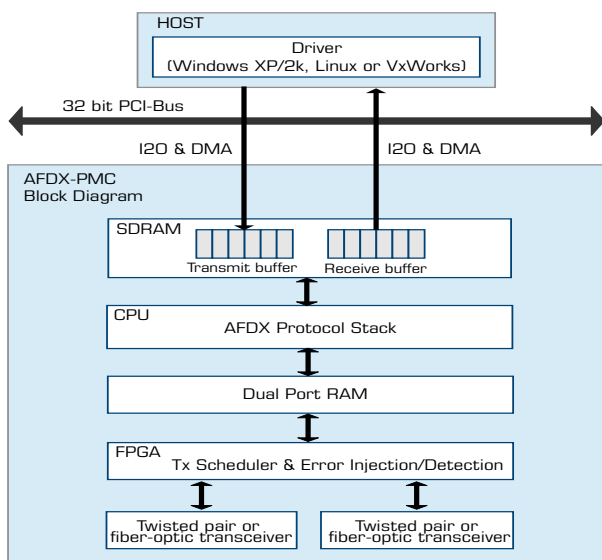

Technical Data

General

- Applicable on PCI, cPCI, PXI, PCIe & VME platforms
- 32 bit @ 33/66 MHz PCI-bus interface
- Compliant with either Airbus or Boeing AFDX® protocol
- Twisted pair or bi-directional fiber-optic SFP transceivers
- Auto-negotiation or fixed 10/100 Mbps transmit rate
- Eight bi-directional discrete I/O lines
- Down to 500 us BAG configuration
- Commercial temp. range: 0 to +55°C

Transmission & Reception

- Traffic shaping via VL and BAG configuration
- Integrity checking & redundancy management
- Up to 256 transmit VLs and 1024 ports per VL
- Up to 2048 receive VLs
- 1 µs Rx frame time-stamp resolution
- Transmit and receive statistics

Error Injection/Detection

- CRC, IFG, short preamble and dribble errors
- RSN insertion enabled/disabled
- Wrong Ethernet type

Triggering

- Tx start, Tx stop or error injection on discrete input
- Discrete output on Tx start, Tx stop or Rx error frame

Software

- C API provided
- LabVIEW VIs available at extra cost
- Drivers available for Windows 2K/XP, Linux or VxWorks.
Please ask for availability of drivers for other platforms
- Optional: software tools for test, simulation & dataloading

AFDX-PMC Ordering Information

- AFDX-PMC-<Connectors>-<Protocol>-<Carrier>
- L PCI, cPCI, PXI, PCIe
 A: Airbus AFDX Protocol
 B: Boeing AFDX Protocol
 T: Twisted Pair
 F: Fiber Optic

Distributor